



Aplicaciones-Applications

Carro para ventanas y puertas correderas, desarrollados a la medida del cliente.

Roller designed for aluminium doors and windows, under the requirements of our customers.

Características-Features

Carro tándem fabricado en zamak con regulación de altura (280 Kg/hoja).

Tandem roller made of zamak with a regulation system (280 Kg per leaf weight supported).

Compuesto por -Made of

Rodamientos de agujas y eje en acero inoxidable AISI 303C

Pista exterior en POM H.

Tornillería en acero inoxidable AISI 304.

Needle bearings with POM H external ring.

Screws in stainless steel AISI 304.

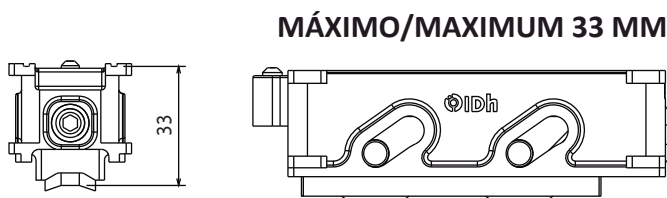
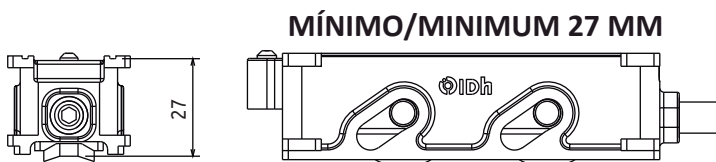
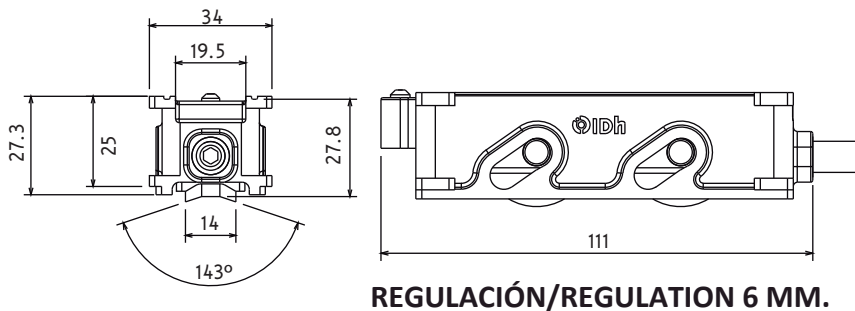

Código - Reference

RU-10002R-IN3 Carro regulable CAT TANDEM

Componentes - Components

Carcasa exterior / exterior casing	Zamak
Carcasa interior / inner casing	Zamak
Rodamientos de agujas-eje / Needle bearings-shaft	INOX
Tornillos / screws	AISI 304

ENSAYO - Test **UNE-EN 13.126-15**

Ensayos mecánicos - Mechanical tests

Laboratorio - Lab : **INTERNO.** / Nº Informe - Report : EP - 00150

Ensayo de Durabilidad:

Carga - Weight **280 kg (Por hoja/by leaf)**

N ciclos - No. Cycles **30.000**

Resultado - Retrieved Result: **Satisfactorio** - Satisfactory

ENSAYO - Test **UNE-EN 1670**

Resistencia a la Corrosión - Resistance to Corrosion

Laboratorio - Lab : **INTERNO.** / Nº Informe - Report : EP - 00150

Resultado Obtenido: **GRADO 4**

Retrieved Result: Grade 4

Embalaje - Packaging

Pack 50 unid. 240X190X105 cms. 15 kgs