



IDh

Innovación y
Desarrollo de herrajes

RU-063-F2

CARRO TANDEM FIJO

Roller for sliding Doors and Windows

Aplicaciones-Applications

Carro para ventanas y puertas correderas, desarrollados a la medida del cliente.

Roller designed for aluminium doors and windows, under the requirements of our customers.

Características-Features

Carro tándem fabricado en nylon reforzado (100 Kg/hoja).

Tandem roller made of reinforced nylon (100 Kg per leaf weight supported).

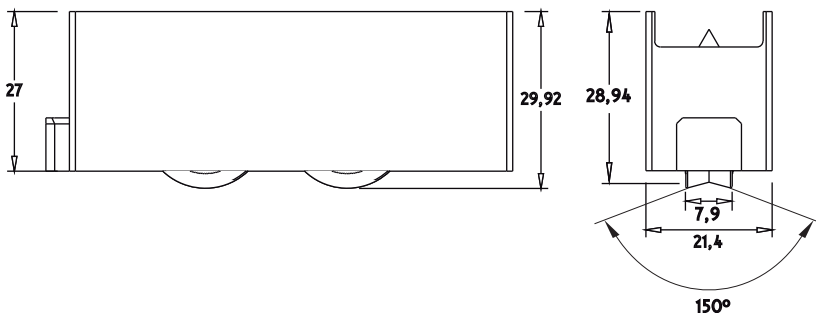
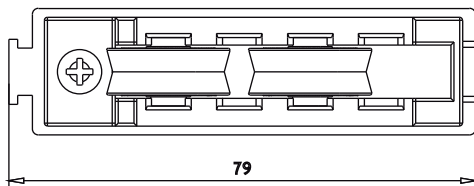

Código - Reference

RU-063-F2 Carro fijo tándem CONFORT. Rodamiento bolas.

Componentes - Components

Carcasa exterior / exterior casing	Poliamida 6 + FV
Rodamientos bolas / balls bearings	Poliamida 6 + FV
Tornillos / screws	AISI 304

ENSAYO - Test UNE-EN 13.126-15

Ensayos mecánicos - Mechanical tests

Laboratorio - Lab : INTERNO. / Nº Informe - Report : EP -

Ensayo de Durabilidad:

Carga - Weight **100 kg** (Por hoja/by leaf)

N ciclos - No. Cycles **25.000**

Resultado - Retrieved Result: **Satisfactorio** - Satisfactory

ENSAYO - Test UNE-EN 1670

Resistencia a la Corrosión - Resistance to Corrosion

Laboratorio - Lab : INTERNO. / Nº Informe - Report : EP -

Resultado Obtenido: **GRADO 4**

Retrieved Result: Grade 4

Embalaje - Packaging

Pack 250 unid. 261x288x226 cms.