



# IDh

Innovación y  
Desarrollo de herrajes

# RU-205-ZR

## CARRO SIMPLE REGULABLE

Roller for sliding Doors and Windows

### Aplicaciones-Applications

Carro para ventanas y puertas correderas, desarrollados a la medida del cliente.

Roller designed for aluminium doors and windows, under the requirements of our customers.

### Características-Features

Carro de de agujas de acero de alta calidad.

Carcasas fabricada en zamak y con regulación de altura.

Carro tandem para puertas de elevadas cargas (150 kg/hoja).

Needle bearing with zamak casing, It includes a height regulation system. 150kg per leaf weight supported.

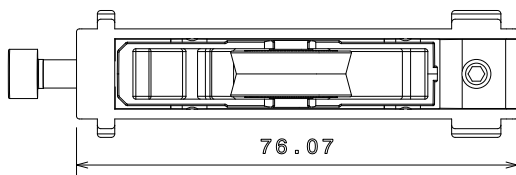
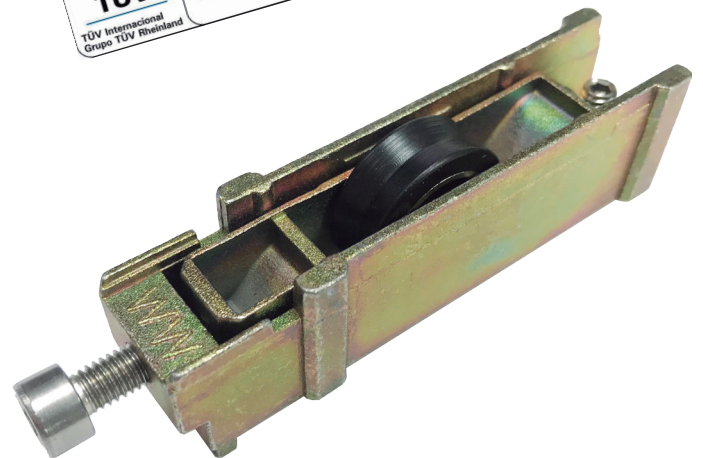

REGULACIÓN/ADJUSTMENT RANGE 7.2 MM.

MÍNIMO/MINIMUM 18.3 MM

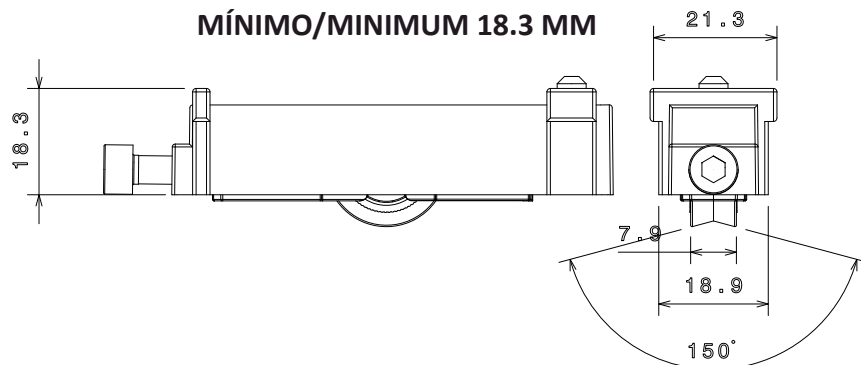

MÁXIMO/MAXIMUM 26.5 MM

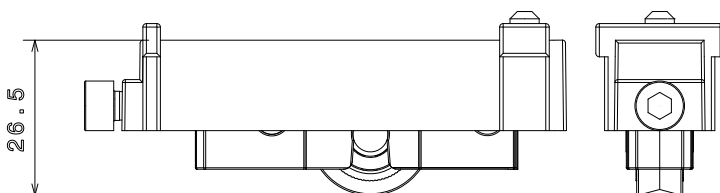

#### Código - Reference

RU-205-ZR Carro regulable simple zamak VC205.

#### Componentes - Components

Carcasa exterior / exterior casing	Zamak
Carcasa interior / inner casing	Zamak
Rodamientos de agujas-eje / Needle bearings-shaft	INOX
Tornillos / screws	AISI 304

#### ENSAYO - Test UNE-EN 13.126-15

##### Ensayos mecánicos - Mechanical tests

Laboratorio - Lab :	INTERNO. /	Nº Informe - Report :	EP - 0034
Ensayo de Durabilidad:			
Carga - Weight	150 kg con 2 ruedas tandem		
N ciclos - No. Cycles	25.000		
Resultado - Retrieved Result:	Satisfactorio - Satisfactory		

#### ENSAYO - Test UNE-EN 1670

##### Resistencia a la Corrosión - Resistance to Corrosion

Laboratorio - Lab :	INTERNO. /	Nº Informe - Report :	EP - 0034
Resultado Obtenido: GRADO 2			
Retrieved Result: Grade 2			

#### Embalaje - Packaging

Pack 50 unid.	240X190X105 cms.	5,75 kgs
---------------	------------------	----------