



IDh

Innovación y
Desarrollo de herrajes

RU-640ZR RU-641ZR-3

CARRO SIMPLE REGULABLE

Roller for sliding Doors and Windows

Aplicaciones-Applications

Carro para ventanas y puertas correderas, desarrollados a la medida del cliente.

Roller designed for aluminium doors and windows, under the requirements of our customers.

Características-Features

Carro de rodamiento de bolas de alta calidad.

Carcasas fabricada en zamak y con regulación de altura.

Carro tandem para puertas de elevadas cargas (50 kg/hoja).

Ball bearing with zamak casing, It includes a height regulation system. 50kg per leaf weight supported.

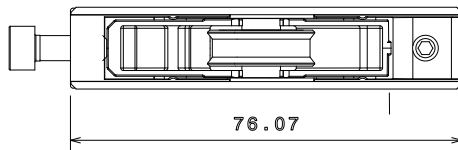
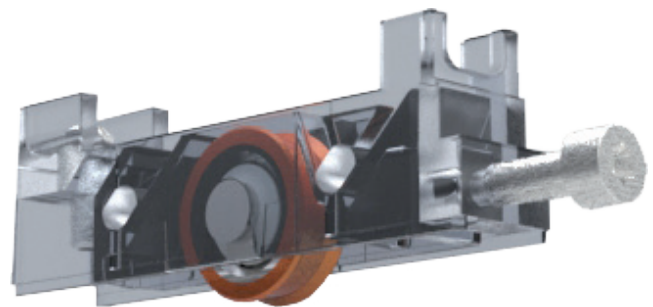

REGULACIÓN/ADJUSTMENT RANGE 7 MM.
MÍNIMO/MINIMUM 29 MM

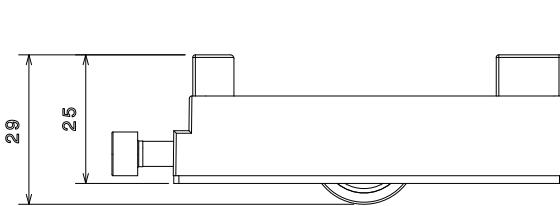

MÁXIMO/MAXIMUM 36 MM

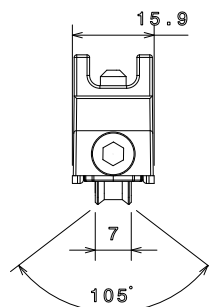
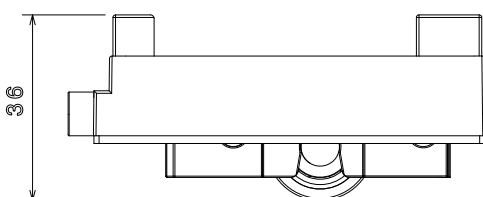

Código - Reference

RU-640ZR Carro regulable simple zamak S-640
RU-641ZR-3 Carro regulable simple ISC-205 cataforesis

Componentes - Components

Carcasa exterior / exterior casing	Zamak
Carcasa interior / inner casing	Zamak
Rodamientos bolas / ball bearings	Resina acetálica
Tornillos / screws	AISI 304

ENSAYO - Test **UNE-EN 13.126-15**

Ensayos mecánicos - Mechanical tests

Laboratorio - Lab : **INTERNO.** / Nº Informe - Report : EP - 0034
Ensayo de Durabilidad:
Carga - Weight **50 kg por hoja**
N ciclos - No. Cycles **25.000**
Resultado - Retrieved Result: **Satisfactorio** - Satisfactory

ENSAYO - Test **UNE-EN 1670**

Resistencia a la Corrosión - Resistance to Corrosion

Laboratorio - Lab : **INTERNO.** / Nº Informe - Report : EP - 0034
Resultado Obtenido: GRADO 2
Retrieved Result: Grade 2

Embalaje - Packaging

Pack 50 unid. 240X190X105 cms. 5,75 kgs